



Static Dissipative Rigid Worksurface 8300 Series

Installation Instructions and User Guide

Table of Contents

Installation Instructions

1.0	Industry Definitions	3
2.0	3M™ Static Dissipative Rigid Worksurface 8300 Series Specifications	3
3.0	Sheet Sizes.....	4
4.0	Packaging Information	4
5.0	Shelf Life.....	4
6.0	Conditioning for Fabrication	4
7.0	Fabrication	5
8.0	Postforming	5
9.0	Substrates.....	6
10.0	Backer.....	6
11.0	Adhesives.....	7
12.0	On-site Installation	8
13.0	Grounding Hardware	9
14.0	Use of Double-Sided Tape	11
15.0	Re-Covering Installed Hard Laminate	11
16.0	Cleaning and Maintenance	11
17.0	Repair.....	11
18.0	Troubleshooting Guide	12

User Guide

1.0	Grounding Hardware	13
2.0	Cleaning and Maintenance	15
3.0	Repair.....	15
4.0	Troubleshooting Guide	15

3M™ Static Dissipative Rigid Worksurface 8300 Series

Installation Instructions

1.0 Industry definitions

- A. Backer: a phenolic sheet placed on the opposite (back) side of the substrate to which the laminate is adhered. The backer is used to offset stresses on the substrate caused by the laminate. It also acts as a moisture barrier (See Section 10.0).
- B. No drip edge: a raised rim on a counter/benchttop/work surface to prevent runoff.
- C. Glue line: the adhesive layer used to adhere laminate to the surface of a substrate.
- D. J-roller 3 inch: a handheld roller used to apply even pressure when bonding laminate to a surface. A pressure of 50 pounds per lineal inch is recommended for most contact adhesives.
- E. NEMA: National Electrical Manufacturers' Association
- F. NEMA LD 3-2000: High-Pressure Decorative Laminate
NEMA LD 3-2000 Annex A: Performance, Applications, Fabrication, & Installation of High-Pressure Decorative Laminate
- G. Off Fall: excess laminate due to dimensional inconsistencies or irregularities in the substrate to which the laminate is applied.
- H. Postforming: bending laminate sheet over or around the edge profile of a counter; this requires special procedures (See Section 8.0)
- I. Tempilaq®/Templistik®: colored marking chalk or wax that is heat-sensitive, i.e., changes color or melts when a certain temperature is reached; used to indicate that the surface of a laminate has reached the proper temperature for thermoforming (325°F). (See Section 8.0)
- J. Waterfall edge: a 90° postformed edge on a counter.

2.0 3M Static Dissipative Rigid Worksurface 8300 Series Specifications

- A. Resistance values: Resistance measurements are used to establish the charge-draining capability of the static dissipative rigid worksurface. The ESD Association evaluates two resistance values in classifying dissipative laminate and other static control surfacing materials. The tests are as follows:
 - 1) Surface to Ground point resistance - Use a 3M™ Test Kit 701 for static control surfaces. Test the resistance between the top surface of the table top and the ground point per ESD Association Standard 4.1 [tested at 72°F (22°C), 50% RH]. The values should be between 1×10^6 - 1×10^9 ohms (1 - 1,000 Megohms).
 - 2) Point to Point resistance - Use a 3M Test Kit 701 for static control surfaces. Test the resistance between two points on the top surface of the table top per ESD Association Standard 4.1 [Tested at 72°F (22°C), 50% RH]. Typical value is 6×10^7 ohms (60 Megohms).

Additional Test:

Ground Point to Ground Point resistance – Perform this test when the worksurface ground connection is to be electrically monitored. Equipment such as the 3M™ Workstation Monitor 724 continuously monitors the ground connection through the interior conductive layer of the laminate. Use a 3M™ Test Kit 701 for static control surfaces to pretest and ensure that the grounding hardware is making sufficient contact to the conductive layer. Connect one of the test leads to each of the two ground hardware items installed on the tabletop. Set the test selector switch to the 10V position. Push the test button and the reading should be less than 1×10^6 ohms (1 Megohm).

- B. Thickness: 0.040 in. nominal
- C. Density: 1.45 grams/cc

- D. Dimensional changes: These changes are measured according to NEMA test methods. Samples are first aged for 24 hours at 70°F (21°C) and 10% relative humidity. The same samples are then aged another 7 days at 100°F (38°C) and 100% RH. The gross change in dimensions (in both the machine and cross-machine directions) is measured after aging.

Machine direction: 1.1 % maximum change
Cross-machine direction: 1.4% maximum change

- E. Use temperature range: -50°F (-46°C) to 150°F (66°C)

NOTE: Continued use above 150°F will deteriorate the laminate. The controlling factor is the glue line. The laminate itself could stand higher temperatures [up to 200°F (93°C)], but the potential problems of shrinkage, adhesive failure, and substrate failure dictate lower use temperatures.

- F. Postformability: 0.5 in. (13 mm) minimum radius when parallel to the machine direction, 0.625 in. (16 mm) minimum radius when perpendicular to the machine direction.

3.0 Sheet sizes

- A. 4 ft. x 8 ft. (48 in. x 96 in.) nominal
Normal shipping size: 48.75 in. x 96.75 in.
Minimum size: 48.125 in. x 96.5 in.
- B. 3 ft. x 12 ft. (36 in. x 144 in.) nominal
Normal shipping size: 36.75 in. x 145.5 in.
Minimum size: 36.125 in. x 144.5 in.
- C. 5 ft. x 12 ft. (60 in. x 144 in.) nominal
Normal shipping size: 61.25 in. x 145.5 in.
Minimum size: 60.5 in. x 144.5 in.
- D. Other sizes
Normal shipping size: nominal dimensions +1.25 in.
Minimum size: nominal dimensions +0.5 in.

4.0 Packaging information

3M™ Static Dissipative Rigid Worksurface 8300 Series is packaged according to 3M packaging standards. The sheets are normally rolled and packed in vertical corrugated container with octagonal cross-section. The maximum number of sheets rolled up in a carton is determined by the weight of filled carton; the normal number of sheets is five.

5.0 Shelf life

3M™ Static Dissipative Rigid Worksurface 8300 Series does not deteriorate with time. However, laminate which is to be postformed should be fabricated within one year of the date of manufacture. Laminate exposed to extremely dry environments will shorten its shelf life. It is always good practice to rotate stock, using the oldest material first.

6.0 Conditioning for fabrication

Preconditioning of laminate prior to fabrication is extremely important. The conditioning will affect dimensional stability, formability, and the overall performance and handling of the laminate during fabrication. Preconditioning is done to minimize dimensional changes due to the loss or gain of moisture. During the process of making the papers used in laminate manufacture, the fibers are generally aligned in the machine direction. Dimensional change is greater across the diameter of the fibers than along their length. As a result, shrinkage is about twice as great in the cross direction as it is in the machine direction. An easy way to identify the machine direction is to observe the sanding marks on the back of the laminate; these run in the machine direction.

- A. Both the laminate and the substrate should be conditioned at approximately 75°F (24°C) and 45-55% RH for a minimum of 48 hours prior to fabrication.
- B. Provision should be made to allow air circulation around the various components of the fabrication process (i.e., laminate, substrate, etc.).
- C. Where cracking may be a problem due to moisture differentials, the laminate should be thoroughly dried out to minimize the rate of shrinkage. Fabricators have not experienced problems with buckling or lifting of laminate when the laminate was dried prior to lamination and then later took on moisture. (Note: Moisture in the laminate enhances its postforming properties.)
- D. Decreasing the ambient humidity - minimizes stress cracking
Increasing the ambient humidity - facilitates postforming

7.0 Fabrication

3M™ Rigid Worksurface 8300 Series is a rigid product and the top surface is very hard. Special tools and procedures are required in order to fabricate this product successfully.

- A. Cutting/sawing/routing:
 1. To avoid chipping during sawing, it is important that the rotation of the blade be such that the teeth of the blade first contact and cut into the decorative (top) surface of the laminate. Therefore, with a hand circular saw, the laminate should be cut with the decorative surface face down. With a table saw, the decorative surface should face up.
 2. Blades and bits used should be carbide-tipped. A blade with more teeth will make a smoother cut. Blades/bits should always be sharp. Recommended saw blades: triple chip grind, 10 – 15 degrees positive rake. Ten inch diameter minimum 80 teeth, twelve inch diameter minimum 100 teeth.
 3. The higher the rotation speed of the blade or bit, the cleaner the cut will be.
⚠Caution: Do not exceed manufacturers recommended rotation speeds.
 4. The laminate should not be forced into a cutting blade, and it must be supported near the blade, especially when cutting unmounted laminate.
 5. When cutting openings into a finished benchtop covered with laminate, never cut the inside corners of the opening at 90° (the point at which each such cut ends can serve as a source for a crack.) Always round such inside corners to a minimum radius to 0.125 in. (3.2 mm). However, the largest possible radius should be used.
 6. After cutting/sawing/routing, the edges of the laminate should always be filed or sanded to remove chips or nicks that may lead to a crack later on.
- B. Sanding:
Sanding and filing should always be directed parallel to or away from the decorative surface.
- C. Drilling:
Recommendations are generally the same as those for sawing. In addition, the material being drilled should be backed to prevent breakout at the bottom of the hole.

8.0 Postforming

- A. The minimum radius around which 3M Rigid Worksurface 8300 should be formed is 0.50 in. when parallel to the machine direction. If the laminate is post-formed perpendicular to the machine direction the minimum radius is 0.625 in.
- B. Laminate sheets can be formed only in a straight line. They cannot be drawn over curved edges (e.g., covering a round tabletop) like vacuum-formable plastic sheets can. The substrate must be clean, smooth, and straight. Parallelism is essential in the moving parts of the forming operation.
- C. In general, the laminate should be only slightly larger than the substrate [0.125-0.25 in. (3.2-6.4 mm)] and should be trimmed after the forming operation is completed. Excessive overhang will tend to crack or buckle during the postforming process. Check the edges of the laminate prior to forming. Any nicks or cracks should be filed smooth before forming; if not, cracks can develop at these rough spots.

- D. The laminate should be stored at room temperature [70°F (21°C)] and 50% R.H. or greater for at least 48 hours before forming. If it is not possible to expose the laminate sheets to this high humidity for 48 hours before forming then proceed with the following. Put a layer of wet paper towels or cloths on the top and bottom of each piece of laminate in the area to be formed. Keep it in this condition for approximately 24 hours. Remove the wet cloths and dry the surface moisture from the back side of the laminate with a dry cloth. This will allow the adhesive to stick to the laminate.
- E. Apply the adhesive according to the manufacturers' recommendations.
- F. Heat to 325°F on backside, 350°- 375°F on front. The laminate must reach optimum bending temperature within 30-60 seconds. Ensure that proper temperature has been reached prior to bending and do not force bending. When laminate is at the proper temperature to be formed, it should be fairly soft and pliable; it need not be forced into shape. Upon reaching temperature, it should be formed immediately. Once formed, the laminate should be held under pressure until cooled.
- G. This optimum bending temperature should be measured; the easiest method of measurement is the Tempilaq®/Tempilstik®. The Tempilaq/Tempilstik mark should be made on the back of the sheet. The temperature should be uniform over the entire laminate surface in the area to be bent; a difference as small as 5°F could result in cracking.
- H. Laminate is more easily formed when the bend is made in the machine direction; that is, parallel to the sanding marks on the back (e.g., along the 8 ft. dimension of a 4 ft. x 8 ft. sheet). This is the orientation of the fibers in the papers; it is easier to bend the material between the fibers than to bend the fibers.
- I. Increasing the ambient humidity by 5% will improve formability, but will also increase the probability of excessive shrinkage.

9.0 Substrates

- A. The standard particle board used for most bench tops is 45 lb. (21 kg) density industrial grade. Although the thickness can vary, 1.125 in. is commonly used. When the top is completed (including the backer), the nominal thickness is 1.25 in. Particle board in 60 lb. density is also available, but is more expensive and the improvement over the more common 45 lb. material is not significant. Unmounted laminate sheets have low impact strength and the type of substrate covered will play a major role in determining the impact strength of the finished product.
 - B. Plywood may be used as a substrate, but it must be very smooth or the grain of the wood will “telegraph” through the laminate.
- ⚠Caution: Voids (knot holes) in the veneers below the top veneer could cause impact failure.**
- C. Masoniter-M® is also a suitable substrate. The untempered type (no oils) is preferred.
 - D. Metal is a suitable substrate. However, if contact adhesive is used, the adhesive on the metal must be dried for a longer time to ensure that solvents have evaporated. If this is not done, a poor bond may result.
 - E. Several materials are not recommended for use as a substrate:

- Underlayment particle board
- Wafer board
- Plaster board
- Gypsum board

10.0 Backer

A backing sheet (“backer”) may be required on the bottom/back of the substrate if (a) the surface area to be covered is large and needs support, or (b) if warping due to moisture variation is a problem. The use of a backer is recommended as good general practice. The three common types of backer used are:

- A. Standard phenolic sheet: most commonly used and dark brown in color.
- B. Balancer sheet: standard laminate material with the decorative/top surface sanded. Material rejected for cosmetic reasons is frequently used.

- C. “Gator Ply”: a commercially available backing material used as moisture barrier. Gator Ply does not have the balancing qualities as a phenolic high pressure-backing sheet. For severe environmental humidity swings, a phenolic backing sheet is recommended to balance the construction.

11.0 Adhesives

Many types of adhesive are available for use in applying laminate. Each type has certain characteristics that make it more suitable for particular applications. Regardless which adhesive is selected, manufacturers' recommendations should be followed carefully.

A. Contact adhesives:

This is the most common type of adhesive used with laminate. It works well on a variety of substrates and does not require sophisticated equipment for fabrication. The only special equipment needed is a nip roll capable of applying 50-75 lbs. per inch (9-16 kg/cm) of roll.

1. Pressure is very important for proper lamination regardless of the type of adhesive used, but it is especially important when using contact adhesives. Solvent entrapment is also important, resulting in a weak bond and latent delamination failures from the substrate.
2. Contact adhesive is available in both solvent and water-based systems. Water-based adhesives are not recommended for use on steel or iron substrates.
3. An important application for contact adhesives is postforming. The adhesive does not require long cure under heat and pressure, and the heat inherent to the postforming operation itself assists in establishing a firm adhesive bond between the laminate and the substrate.
4. It is recommended that a minimum of 80% of the surface area of both the laminate and the substrate be covered with the contact adhesive. There is a tendency to apply insufficient adhesive. The result is that the adhesive bond will be stronger in some spots than in others, causing stresses in the laminate that may lead to cracking. For this reason, “spot bonding” of the laminate to the substrate should never be done. On the other hand, because most contact adhesives are neoprene-based, too much adhesive can also cause problems like delamination or movement of the adhesive itself.
5. The edges of the substrate surface should be double-coated with adhesive prior to lamination.
⚠Caution: When applying the second coat around the edges, make sure the first coat is dry and the solvent had a chance to flash off.
6. Laminate will “move” slightly with varying humidity conditions. Contact adhesives permit this movement to a greater extent than do thermosetting adhesives.
7. Typical of contact adhesives, it is not possible to lift and reposition the laminate once contact has been established between the adhesive-coated laminate and substrate.
8. The evaporation of solvent from the contact adhesive has a cooling effect that may cause moisture to condense on the surface of the adhesive. This is referred to as “blushing” and can cause poor bonding. “Force drying” the adhesive with hot air should reduce this problem.

NOTE: Flashing off of the solvent is dictated by the humidity in the work environment. High humidity environments require additional time for this process.

B. Thermosetting adhesives:

These adhesives require time and/or heat for proper curing. A press is needed to apply pressure while the adhesive cures; 20 psi (1.41 kg/sq cm) is typical. Most thermosetting adhesives are two-part systems with a specified “pot life,” i.e., they must be used within a limited amount of time once the two parts are mixed together.

1. Resorcinol: This is the best adhesive for use in applications where cracking due to humidity variations may be a problem. Resorcinol is recommended where good resistance to water and heat is required.
2. Epoxy: This adhesive is good for applications calling for gap-filling and low shrinkage. It is primarily used to bond laminate to metal substrates. Because epoxy adhesives are generally “100% solids” (solvent-free), there is no solvent to flash off and problems related to solvent being trapped in the substrate do not exist. Like Resorcinol, epoxies are good adhesives for applications in which cracking due to humidity variations could be a problem.

- C. Recommended Adhesive
Solvent-Based: 3M™ Scotchgrip™ High Performance Contact Adhesive 1357
Adhesive Water-Based: 3M™ Fastbond™ Contact Adhesive 30-NF (Neutral or Green)
Adhesive Water-Based: 3M™ Fastbond™ Contact Adhesive 2000-NF
Contact 3M Industrial Adhesives and Tape Division: 1-800-362-3550
- D. Handling and Safety Precautions:
Read all Health Hazard, Precautionary, and First Aid statements found in the Material Safety Data Sheet. and/or product label of chemicals prior to handling or use.

12.0 On-site Installation

Standard installation procedures for laminate apply in this situation as well, but a few other specific differences should be noted:

- A. Contact adhesive is generally recommended for on-site installation because a press is not required to cure the adhesive and because turn-around time is short.
- B. Wooden dowels should be used to separate the adhesive-coated laminate from the adhesive coated substrate prior to bonding them together. This procedure allows proper alignment of the two surfaces. Once the laminate is positioned, the dowels are individually removed and the adhesive surfaces are allowed to bond together.
- C. Adequate pressure is absolutely essential to ensure a good bond. The more pressure, the better the bond will be. To enhance the bond and to eliminate air pockets, a J-roller should be used to roll the laminate after it has been applied, rolling from the center of the laminate outward.

13.0 Grounding Hardware

Several products are available to properly ground worksurfaces covered with static-dissipative laminate and to ground personnel and other equipment operating at such workstations. A line drawing follows the explanation of each system:

- A. 3M™ Hard Laminate Grounding System 3041: This is a system that includes the hardware (ground cord, bolt, nut, star, washer, etc.) needed to ground a benchtop covered with dissipative laminate. The components of the kit allow several different methods of grounding to be used. In each method, a star washer cuts through the top decorative layer of the laminate to make electrical contact with the conductive layer beneath. The ground cord can be attached to either the top or the underside of the bench.

3M™ Hard Laminate Grounding System 3041 Typical Installations

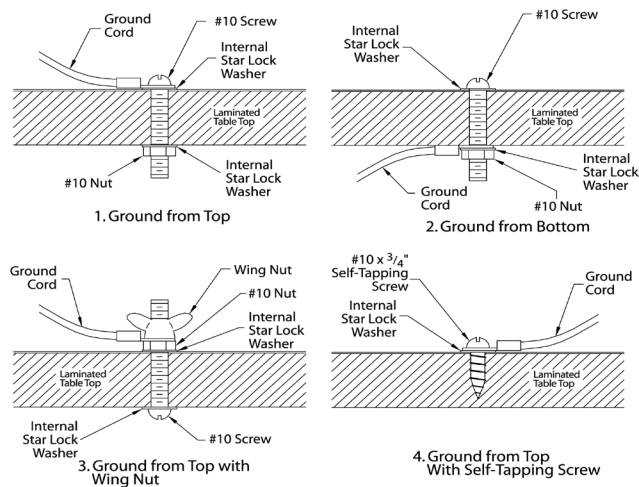

- B. 3M™ Wrist Strap Grounding System 3042: This is an accessory product that can be permanently mounted to a laminate-covered workbench. It is designed to allow the operator(s) at that bench to connect wrist strap cords to the same ground to which the laminate benchtop is connected. The 3M Grounding System is a small module containing two banana jacks, side-by-side, which will accept the banana plugs on the ground cords of standard static control wrist straps.

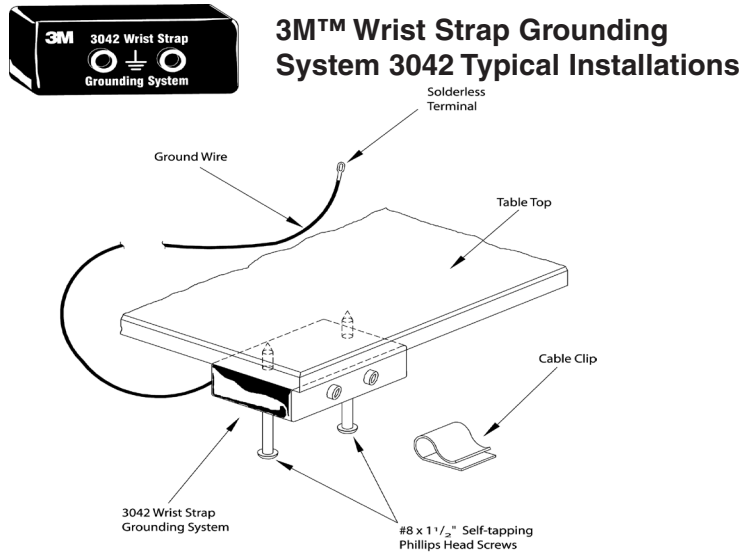

- C. 3M™ Common Point Grounding System 3047: This is a multi-terminal common point grounding device that mounts on the underside or on top of a laminate-covered workbench. It not only grounds the work surface laminate, but also allows up to six additional static control products to be connected to that same ground point through a common buss. If a 3M Grounding System is used to ground a dissipative laminate work surface, a 3M™ Grounding Kit for Static Protective Hard Laminate is not necessary.

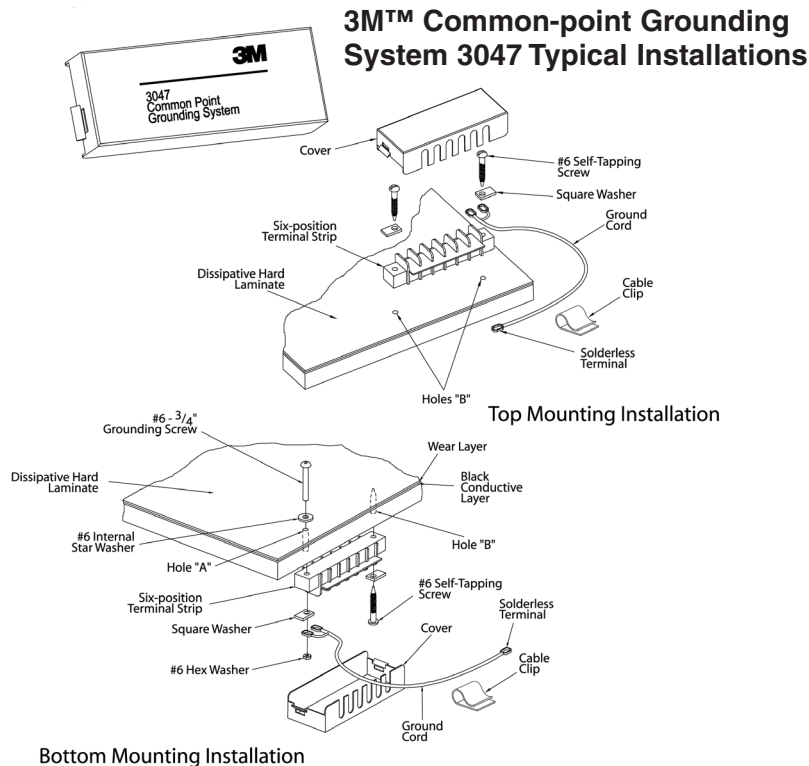

14.0 Use of Double-sided Tape

Rather than install static-dissipative laminate to benchtops with adhesives in the traditional manner, some customers attempt to adhere the laminate with double-coated tape (i.e., tape with adhesive on both sides). Those customers should be made aware that there are several shortcomings associated with this procedure.

- A. Internal stresses within the laminate unique to the manufacturing process as well as variations in the moisture content of the ambient air can prevent the laminate sheets from laying flat. The adhesives typically used to install laminate (described in Section 11.0) are strong enough to overcome these stresses, but double-sided tape is generally not.
- B. On a laminate benchtop, the majority of the impact strength of the finished top is the result of the uniform and intimate contact between the laminate and the substrate. Using double-sided tape offers support for the laminate only at those spots where the tape is applied.

15.0 Re-covering Installed Laminate

While most decorative commercial laminate can be re-covered with additional laminate by sanding the existing surface, cleaning it, and re-applying adhesive, this practice will not work well with 3M™ Static Dissipative Rigid Worksurface 8300 Series. The 3M laminate is manufactured with a special, tough, abrasion-resistant coating that resists sanding. Therefore, adhesive will not bond well to the surface.

16.0 Cleaning and Maintenance

- A. The 3M rigid worksurface is readily cleaned with 3M™ Static Control Worksurface Mark Remover 8001. It can also be cleaned with warm water and mild detergents. Many commercially available detergents are suitable, including common household dishwashing liquids.
- B. Nonabrasive, commercially available surface cleaners such as glass cleaners or products similar to SoftScrub™ are suitable. Cleaners containing abrasives or strong acids or alkalines should be avoided.
- C. Stains such as those caused by solder flux, varnishes, ink, etc., can be removed with organic solvents (alcohols, ketones, xylene, mineral spirits). Such stains can also be removed by a two-minute exposure to a 5% hypochlorite bleach (common laundry bleach) followed immediately by a clean water rinse.
- D. The surface should be protected from heat and from cuts and gouges by means of a hot pad and/or cutting board. 3M Rigid Worksurfaces will not be affected by drops of molten solder, but will blister if a soldering iron or some other intensely hot object is left on the surface. Blistering will occur at approximately 400°F (204°C).
- E. ANYTIME THE LAMINATE SURFACE IS CLEANED OR OTHERWISE AFFECTED, THE ELECTRICAL PERFORMANCE SHOULD BE VERIFIED.

17.0 Repair

- A. Colored paste can be used to visually repair minor defects in the top surface.
- B. Laminate that was adhered with contact adhesive and that lifts from the substrate can be readhered by applying heat and pressure. A simple method is to place a piece of cloth over the problem area and then iron it with a household iron.

18.0 Troubleshooting Guide

Symptom	Problem Causes	Recommendations
Cracking	<p>Moisture differences between substrate and laminate</p> <p>Poor adhesive bond</p> <p>Substrate flexing</p> <p>Stress points</p>	<p>Condition properly prior to lamination Pre-condition laminate to match end-use conditions</p> <p>Follow manufacturer's recommendations closely For highest bond, use thermoset adhesives</p> <p>Use thicker substrate Support substrate with backer</p> <p>Radius inside corners of openings to 0.125 in. (3.2 mm) minimum</p>
Poor Postforming	<p>Cracking at bend point</p> <p>Backside of laminate too cool</p> <p>Heating too slowly; laminate cures before bending is completed</p> <p>Laminate too dry</p> <p>Substrate uneven</p>	<p>Heat to 325°F on backside, 350°-375°F on front</p> <p>Ensure that proper temperature has been reached prior to bending Do not force bending</p> <p>Laminate must reach optimum bending temperature within 30-60 sec</p> <p>Pre-condition laminate properly, add moisture</p> <p>Ensure that substrate is smooth, straight, and of even curvature Substrate should be larger than laminate</p>
Surface changes	<p>Discoloration</p> <p>Due to sunlight</p> <p>Due to chemicals</p> <p>Due to heat</p> <p>Dents/depressions due to substrate imperfections</p>	<p>Laminate not intended for outdoor use Keep laminate away from direct sunlight</p> <p>Avoid prolonged exposure to bleaches, acids, alkalis</p> <p>Remove/insulate heat source</p> <p>Use higher-density, thicker, or smoother substrate</p> <p>Cover at least 80% of the bond surfaces with adhesive</p>
Shrinkage	<p>Improper conditioning</p> <p>Adhesive failure</p>	<p>Pre-condition materials properly</p> <p>Increase amount of adhesive and pressure</p>
Chipping	<p>Improper tools</p> <p>Slow cutting speed</p> <p>Unsupported laminate</p>	<p>Use carbide-tipped blades with teeth then cut into the top surface of the laminate</p> <p>Increase cutting speed</p> <p>Support laminate sheet at the cutting point</p>
Blistering	<p>Excessive heat</p>	<p>Remove/insulate heat source</p>
Bumps	<p>Foreign particles trapped between laminate and substrate</p> <p>Adhesive lumps between laminate and substrate</p>	<p>Clean surfaces thoroughly before laminating</p> <p>Heat the surface and apply pressure (roller, wood block and hammer, etc.)</p>

3M™ Static Dissipative Rigid Worksurface 8300 Series

User Guide

1.0 Grounding Hardware

Several products are available to properly ground worksurfaces covered with static-dissipative laminate and to ground personnel and other equipment operating at such workstations. A line drawing follows the explanation of each system:

- A. 3M™ Hard Laminate Grounding System 3041: This is a system that includes the hardware (ground cord, bolt, nut, star, washer, etc.) needed to ground a benchtop covered with dissipative laminate. The components of the kit allow several different methods of grounding to be used. In each method, a star washer cuts through the top decorative layer of the laminate to make electrical contact with the conductive layer beneath. The ground cord can be attached to either the top or the underside of the bench.

3M™ Hard Laminate Grounding System 3041 Typical Installations

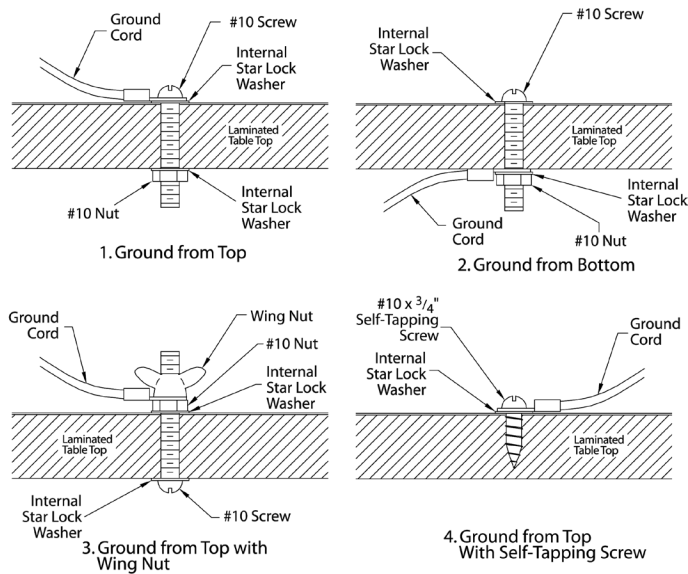

- B. 3M™ Wrist Strap Grounding System 3042: This is an accessory product that can be permanently mounted to a laminate-covered workbench. It is designed to allow the operator(s) at that bench to connect wrist strap cords to the same ground to which the laminate benchtop is connected. The 3M Grounding System is a small module containing two banana jacks, side-by-side, which will accept the banana plugs on the ground cords of standard static control wrist straps.

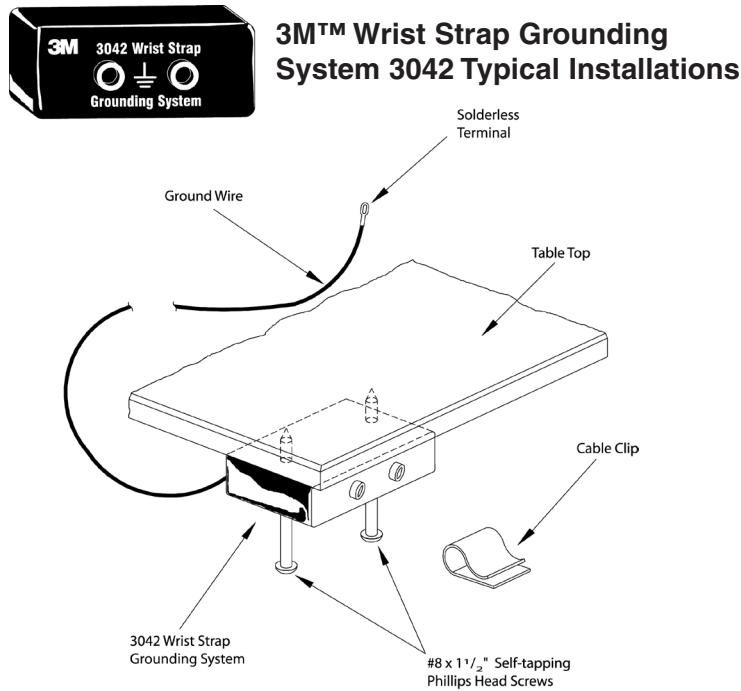

- C. 3M™ Common Point Grounding System 3047: This is a multi-terminal common point grounding device that mounts on the underside or on top of a laminate-covered workbench. It not only grounds the work surface laminate, but also allows up to six additional static control products to be connected to that same ground point through a common buss. If a 3M Grounding System is used to ground a dissipative laminate work surface, a 3M™ Grounding Kit for Static Protective Hard Laminate is not necessary.

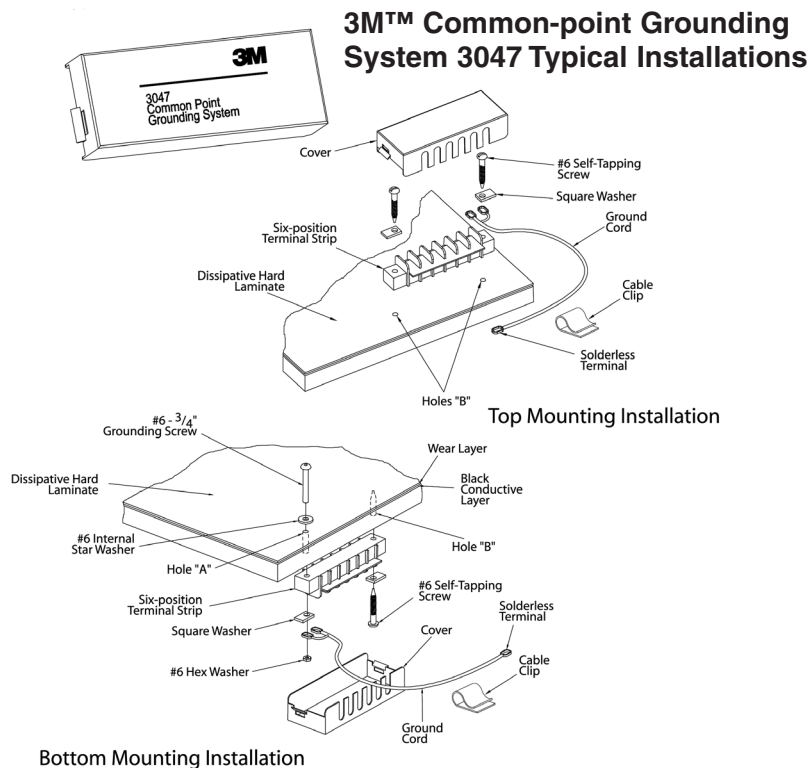

2.0 Cleaning and Maintenance

- A. The 3M™ Rigid Worksurface 8300 Series is readily cleaned with 3M™ Static Control Worksurface Mark Remover 8001. It can also be cleaned with warm water and mild detergents. Many commercially available detergents are suitable, including common household dishwashing liquids.
- B. Nonabrasive, commercially available surface cleaners such as glass cleaners or products similar to SoftScrub™ are suitable. Cleaners containing abrasives or strong acids or alkalines should be avoided.
- C. Stains such as those caused by solder flux, varnishes, ink, etc., can be removed with organic solvents (alcohols, ketones, xylene, mineral spirits). Such stains can also be removed by a two-minute exposure to a 5% hypochlorite bleach (common laundry bleach) followed immediately by a clean water rinse.
- D. The surface should be protected from heat and from cuts and gouges by means of a hot pad and/or cutting board. 3M Rigid Worksurfaces will not be affected by drops of molten solder, but will blister if a soldering iron or some other intensely hot object is left on the surface. Blistering will occur at approximately 400°F (204°C).
- E. ANYTIME THE LAMINATE SURFACE IS CLEANED OR OTHERWISE AFFECTED, THE ELECTRICAL PERFORMANCE SHOULD BE VERIFIED.

3.0 Repair

- A. Colored paste can be used to visually repair minor defects in the top surface.
- B. Laminate that was adhered with contact adhesive and that lifts from the substrate can be readhered by applying heat and pressure. A simple method is to place a piece of cloth over the problem area and then iron it with a household iron.
- C. While most decorative commercial laminate can be re-covered with additional laminate by sanding the existing surface, cleaning it, and re-applying adhesive, this practice will not work well with 3M™ Static Dissipative Rigid Worksurface 8300 Series. The 3M laminate is manufactured with a special, tough, abrasion-resistant coating that resists sanding. Therefore, adhesive will not bond well to the surface.

4.0 Troubleshooting Guide

Surface changes	Discoloration	
	Due to sunlight	Laminate not intended for outdoor use Keep laminate away from direct sunlight
	Due to chemicals	Avoid prolonged exposure to bleaches, acids, alkalis
	Due to heat	Remove/insulate heat source
	Dents/depressions due to substrate imperfections	Use higher-density, thicker, or smoother substrate Cover at least 80% of the bond surfaces with adhesive

Handling and Safety Precautions

Read all Health Hazard, Precautionary, and First Aid statements found in the Material Safety Data Sheet and/or product label of chemicals, prior to handling to use.

3M, Scotchgrip, and Fastbond are trademarks of 3M Company.
Tempilaq/Tempilstik is a registered trademark of the Tempil Corporation.
Softscrub is a trademark of Clorox.
Masonite is a registered trademark of Masonite Corporation.

Important Notice

All statements, technical information, and recommendations related to 3M's products are based on information believed to be reliable, but the accuracy or completeness is not guaranteed. Before using this product, you must evaluate it and determine if it is suitable for your intended application. You assume all risks and liability associated with such use. Any statements related to the product which are not contained in 3M's current publications, or any contrary statements contained on your purchase order shall have no force or effect unless expressly agreed upon, in writing, by an authorized officer of 3M.

Warranty; Limited Remedy; Limited Liability.

This product will be free from defects in material and manufacture for a period of one (1) year from the time of purchase. **3M MAKES NO OTHER WARRANTIES INCLUDING, BUT NOT LIMITED TO, ANY IMPLIED WARRANTY OF MERCHANTABILITY OR FITNESS FOR A PARTICULAR PURPOSE.** If this product is defective within the warranty period stated above, your exclusive remedy shall be, at 3M's option, to replace or repair the 3M product or refund the purchase price of the 3M product. **Except where prohibited by law, 3M will not be liable for any indirect, special, incidental or consequential loss or damage arising from this 3M product, regardless of the legal theory asserted.**



Electronic Solutions Division

6801 River Place Blvd.
Austin, TX 78726-9000
www.3M.com/electronics



Recycled paper
40% Pre-consumer waste paper
10% Post-consumer waste paper

Litho in USA
© 3M 2006 78-8136-3801-8-A